



Steca Solarix

Alpha, Gamma, Sigma, Omega

Steca's Solarix series is the world's most sold PV charge controller for the use in medium sized solar home systems and PV power supplies in the range of 8 to 30 A (up to 900 Wp). The heart of the controller is the integrated circuit called ATONIC®, which contains the regulation software based on a self learning algorithm. The result is an accurate state of charge (SOC) metering of the battery, the best insurance for a long battery lifetime.

Features

- PWM shunt battery charging
- State of charge (SOC) battery regulation
- Boost-, Equalising-, Float charging
- Automatic load reconnection
- Automatic selection of voltage (12 V / 24 V)
- Temperature compensation
- Positive grounding (or) Negative grounding on one terminal
- Field adjustable parameters by jumpers on PCB
- Optional: operates load only by night
- Optional: external temperature sensor

Protection functionality

- High voltage disconnect (HVD)
- Low voltage disconnect (LVD)
- Depth of discharge disconnection (DOD)
- Reverse polarity of solar modules
- Reverse polarity of load & battery
- Short circuit of solar modules
- Short circuit of load
- Over temperature
- Over voltage
- Lightning protection by varistor
- Open circuit battery
- Reverse current at night

Displays

- PV system LED
- state of charge LED

Technical data

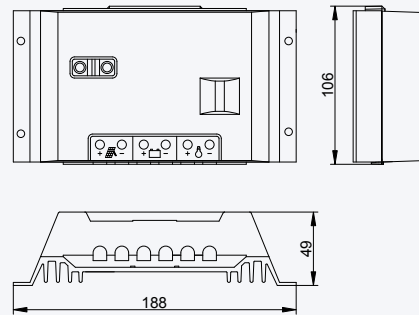

Solar Charge Controller	Alpha	Gamma	Sigma	Omega
System voltage	12 V (24 V)			
Max. module input short circuit current	8 A	12 A	20 A	30 A
Max. load output current	8 A	12 A	20 A	30 A
Max. self consumption	5 mA			
End of charge voltage (float)	13.7 V (27.4 V)			
Boost charge voltage; 1 h	14.4 V (28.8 V)			
Equalisation charge (deactivated for gel accu); 1 h	14.7 V (29.4 V)			
Reconnection setpoint (SOC/LVR)	> 50 % / 12.6 V (25.2 V)			
Deep discharge protection (SOC/LVD)	< 30 % / 11.1 V (22.2 V)			
Ambient temperature allowed	-25 °C...+50 °C			
Terminal size (fine/single wire)	16 mm ² / 25 mm ²			
Enclosure protection class	IP 22			
Weight	420 g			
Dimensions l x w x h	188 x 106 x 49 mm			

Technical data at 25 °C / 77 °F

Power class

8 A - 30 A



Certificates

- Approved for Worldbank funded projects in Indonesia by TÜV
- Listed for Worldbank funded projects in Bangladesh, China, Laos, Nepal, Sri Lanka, Uganda
- Certificate ONE / KfW funded projects in Morocco
- Compliant to the use in tropical areas (DIN IEC 68 part 2-30)
- Conform to European Standards (CE)
- UL listing in 1999
- Made in Germany
- TÜV Worldbank spec
- ThermieB: SUP-995-96 (Morocco)
- Manufactured in a DIN EN ISO 9001:2000 and DIN EN ISO 14001 facility